

INSTRUCTIONS FOR

0. GENERAL SAFETY INFORMATION, WARNINGS & CAUTIONS
1. INSTALLATION
2. THE USER
3. SERVICING
4. DISPOSAL

AQUABREAK AB5 BREAKTANK & PUMPSET

FOR BACKFLOW PROTECTION TO FLUID CATEGORY 5









XLM-300400 ISSUE 6 08/03/2022

Head Office: AGM House, London Rd, Copford, Colchester, Essex CO6 1GT UK
Tel: 01206 215121 Email: aftersales@agm-plc.co.uk

These pumpsets are used for increasing the supply pressure of cold potable water whilst also providing back flow protection to fluid category 5.

CONTENTS

		0. GENERAL SAFETY INFORMATION	3
			
0.1		WARNINGS.....	4
0.2		CAUTIONS FOR INSTALLATION	4
0.3		CAUTIONS FOR OPERATION/USER	6
0.4		CAUTIONS FOR MAINTENANCE	6
1. INSTALLATION INSTRUCTIONS			7
1.1		ADDITIONAL WARNINGS	7
1.2		ADDITIONAL CAUTIONS.....	7
1.3		PROCEDURE	7
1.3.1		OFF-LOADING AT SITE.....	7
1.3.2		LOCATION	8
1.3.3		FIXING.....	8
1.3.4		PIPEWORK.....	9
1.3.5		FLOW THROUGH VESSELS	10
1.3.6		ELECTRICAL.....	10
2. USER INSTRUCTIONS			12
2.1		CUSTOMER ASSURANCE	12
2.2		COMMISSIONING.....	13
2.3		OPERATING INSTRUCTIONS.....	14
2.3.1		ADDITIONAL WARNINGS	14
2.3.2		ADDITIONAL CAUTIONS	14
2.3.3		NORMAL OPERATION.....	14
2.3.4		TROUBLE SHOOTING GUIDE.....	15
2.4		MAINTENANCE INSTRUCTIONS.....	16
2.4.1		ADDITIONAL CAUTIONS	16
2.4.2		PROCEDURE.....	16
3. SERVICING			17

3.1	MAINTENANCE AND CARE OF YOUR EQUIPMENT	17
3.2	LEGAL REQUIREMENTS.....	17
3.3	SERVICE CONTACTS.....	17
4.	DISPOSAL.....	17
	EU DECLARATION OF CONFORMITY	18
	OPERATING PARAMETERS.....	18



0. GENERAL SAFETY INFORMATION



- These instructions are intended for the installer/operator/user/maintenance of this equipment and must be kept with the equipment, for the life of the equipment and made available to all persons. Please read GENERAL SAFETY INFORMATION 0.0, WARNINGS 0.1 and CAUTIONS 0.2, 0.3 & 0.4 before doing anything else, and then follow them carefully.
- The unit must only be installed/operated/used/maintained by a competent person; A *competent person is someone who is technically competent and familiar with safety practices and the hazards involved.*
- Hydraulic Accumulators/Expansion Vessels installed as part of/in conjunction with this equipment, with Pressure x Volume above 250 Bar-litres, require regular formal inspection by a *competent person*. This is a Legal Requirement under the “Pressure Systems Safety Regulations” (PSSR) and the Owner/User should be made aware of their responsibility for this. (see section 3. Servicing).
- Failure to install/operate/use/maintain the equipment as recommended below could cause damage to the equipment any anything subsequently connected to it, and invalidate the warranty provided by AquaTech-Pressmain to the buyer.
- Any damage caused to the equipment by misapplication, mishandling or misuse could lead to risk of **Electrocution, Burns, Fire, Flooding or injury to people or property** dependent upon the circumstances involved.
- This equipment contains moving/rotating parts that must remain guarded. Removal of or missing guards could lead to serious personal injury.
- This equipment automatically restarts after a power interruption.
- We accept no responsibility or liability for any consequences or damage/losses due to misapplication, mishandling or misuse of the equipment.
- It should be noted that the assembly of pressure equipment on site under the responsibility of the user (or his representative) is not subject to the Pressure Equipment Directive 2014/68/EU. (National legislation covering assembly on site will apply)
- The latest version of this instruction manual with up to date safety information can be downloaded from our website at www.aquatechpressmain.co.uk



0.1 WARNINGS

- 0.1.1 Do not touch any live parts for at least 5 minutes after switching off the electricity supply. Failure to observe this will constitute a severe Electric shock and/or Burns hazard and may be lethal.
- 0.1.2 The equipment is only suitable for earth referenced supplies and must be permanently earthed to avoid Electric shock hazard.
- 0.1.3 Metal parts (e.g. heat sinks) may reach temperatures of 90 degrees centigrade and will constitute a Burns hazard.
- 0.1.4 The equipment must not be pressurised beyond the maximum working pressure as stated on pumps/pipework/vessels/control panel otherwise serious mechanical damage/destruction could occur causing injury to people or property.
- 0.1.5 The equipment must not be heated/chilled beyond the maximum/minimum working temperature as stated on pumps/pipework/vessels/control panel otherwise serious mechanical damage/destruction could occur causing injury to people or property.
- 0.1.6 Any damage to equipment, pumpset, vessels, pipework or system components caused by misapplication, mishandling or misuse could lead to Electric shock hazard, Burns hazard, Fire hazard, Flooding hazard or cause injury to people or property.
- 0.1.7 This equipment may contain moving/rotating parts that must remain guarded. Removal of or missing guards could lead to serious personal injury.
- 0.1.8 Pressure vessels must never be disassembled whilst in use, they contain high pressure air/gas charge which could cause injury to people or property.
- 0.1.9 Ensure the base/foundation/plinth/wall to which the equipment is to be attached is sufficiently strong enough to carry the entire mass of the equipment including the water that it will contain under worst-case fault conditions. E.g. fully saturated pressure vessel with no air charge, break tank full to overflowing, etc. Failure to observe this could cause serious mechanical damage/destruction resulting in injury to people or property.
- 0.1.10 This equipment contains a fluid which may under certain circumstances leak/drip/spray fluid (e.g. servicing, repair or malfunction). Ensure any fluid discharge will not cause damage to the surroundings by taking appropriate action. E.g. install in a place that will not be damaged by leakage or install in a bunded area with adequate drainage.



0.2 CAUTIONS FOR INSTALLATION

- 0.2.1 READ GENERAL SAFETY INFORMATION 0.0, WARNINGS 0.1 and CAUTIONS 0.2, 0.3 & 0.4
- 0.2.2 The unit should only be installed/operated by a competent person; *A competent person is someone who is technically competent and familiar with safety practices and the hazards involved.*
- 0.2.3 Do not lift the pumpset by pipework. Lift the pumpset by the container pallet using a pallet/forklift or crane by passing strops underneath the skid using a spreader bar. Failure to utilise these facilities will result in damage to the pumpset.
- 0.2.4 Store in a dry place to avoid damp conditions deteriorating the equipment.
- 0.2.5 Protect against dirt, damage and frost. It is absolutely essential that no foreign matter such as pipe thread swarf, welding slag, grit or stones are allowed to enter the set. Debris of this type can cause severe damage to the mechanical seals, diaphragms and impeller. Frost/freezing will damage pumps/pipework and control panel components.
- 0.2.6 The equipment is only suitable for installation in a clean, dust free indoor environment, with adequate protection from heat and frost, and sufficient ventilation to ensure cooling of the motors. Ambient air temperature should be between 5 and 40 degrees centigrade, non-condensating. Operation outside of these conditions could seriously damage the equipment.

-
- 0.2.7** If the equipment were to be stored or taken out of service for a period of time (e.g. 1 week or more), then we would recommend draining the equipment of all water/liquid (with due regard to any local regulations) to prevent frost damage to components. When restarting is required we would recommend commissioning by our authorised service agent.
- 0.2.8** Ensure the base/foundation/plinth/wall to which the equipment is to be attached has sufficient mass compared to the equipment, in order to avoid noise/vibration transmission. E.g. the mass of the base should be at least five times the mass of the equipment.
- 0.2.9** Ensure the electrical supply is the correct voltage, current, frequency and type for the equipment supplied and that suitable circuit protection equipment is installed in the supply. Incorrect electrical installation could be an electric shock/burns/fire hazard.
- 0.2.10** When accessing the control panel to make electrical connections adopt anti-static procedures e.g. wear anti-static earthed wristband, to avoid risk of damaging the controller.
- 0.2.11** All products that are packaged to include Pressure vessel(s)/Hydraulic Accumulator(s)/Expansion Vessel(s) are classed as “Assemblies” under the Pressure Equipment Directive (PED). Where units are despatched with “Loose” vessel(s) for assembly on site it is absolutely essential that they be installed as detailed in the instructions using the fittings provided where appropriate. Failure to observe this will nullify compliance with the PED and may present a safety hazard. Your warranty may also be affected.
- 0.2.12** Where Hydraulic Accumulator(s)/Expansion Vessel(s) are supplied as a loose item, they must be installed/connected correctly before operating the equipment, otherwise serious damage from over-pressure/pump overheating could occur.
- 0.2.13** Do not operate this equipment/pumpset prior to commissioning (section 2.2) This could cause irreparable damage to equipment/pumpset/pipework/system components.
- 0.2.14** Isolate the equipment/pumpset before pressure testing system. Excess pressure could irreparably damage the pressure transducer, pressure switches (where fitted) and the diaphragms of pressure vessel/hydraulic accumulators.
- 0.2.15** It is the installers’ responsibility to ensure subsequent pipework etc can accept the pressures generated by the equipment/pumpset and to install an overpressure safety device into the system with due respect to the suction pressure present on the pumpset, the pump closed valve pressure stated on the pump, the maximum working pressure stated on any of the attached pressure vessels and any other device connected to the system e.g. boilers, calorifiers etc.
- 0.2.16** When chlorination of the system is carried out, ensure that any residual chlorine is removed by thorough flushing as detailed in the HSE approved code of practice L8, to avoid damaging the equipment/pumpset. The normal level of chlorination is up to 2 parts per million (ppm), but shock dosing for sterilization purposes, at 25-50 ppm for 24-48 hours is acceptable as long as all chlorine is removed once the process is complete. Chlorination beyond these limits could seriously damage pumpset components and WILL NOT be covered by the warranty.
- 0.2.17** The installer/user is responsible for the installation of the correct earthing and protection according to valid national and local standards. All operations must be carried out by a suitably qualified person.
- 0.2.18** The equipment is only suitable for earth referenced supplies and must be permanently earthed to avoid electric shock hazard.
- 0.2.19** The equipment must be permanently earthed with appropriate sized Earthing.
- 0.2.20** We recommend the use of a 30mA RCD to provide electrical safety.
- 0.2.21** Never perform high voltage resistance tests on control panels, variable speed drives/motors without first disconnecting the panel/drive/motor from the circuit being tested as this will damage the built in electronic components.
- 0.2.22** Metal parts (e.g. heat sinks) may reach temperatures of 90 degrees centigrade.
- 0.2.23** Where “Expansion vessels” are used on Domestic hot water systems (DHWS) or LTHW heating system pressurisation units, the temperature of the fluid returning to the vessels should not exceed 70 degrees Centigrade for standard vessels or 100 degrees centigrade for Solar vessels, as this could damage the vessel diaphragm. Where the temperature exceeds 70/100C an intermediate cooling vessel should be fitted.
- 0.2.24** Where “Expansion vessels” are used on Domestic hot water systems (DHWS) or LTHW heating system pressurisation units, the glycol content in the water must not exceed 50%.
- 0.2.25** Drain cocks/valves and air bleed screws must not be left open as this could cause flooding.
-

- 0.2.26 Ensure the Y strainer (100um) and isolation valve is installed on the inlet to the break tank, failure to install these will cause the solenoid to jamb and overflow the break tank.
- 0.2.27 Ensure a pressure reducing valve set at a maximum of 3.0Bar is installed on the inlet to the break tank if the mains water supply pressure exceeds 3.0Bar.



0.3 CAUTIONS FOR OPERATION/USER

- 0.3.1 READ GENERAL SAFETY INFORMATION 0.0, WARNINGS 0.1 and CAUTIONS 0.2, 0.3 & 0.4
- 0.3.2 The unit should only be operated/used by a competent person; *A competent person is someone who is technically competent and familiar with safety practices and the hazards involved.*
- 0.3.3 The Owner/User of this equipment has a Legal Responsibility to ensure that it is subject to regular formal inspections. See Section 3. Servicing, for details.
- 0.3.4 Where Hydraulic Accumulator(s)/Expansion Vessel(s) are supplied as a loose item, they must be installed/connected correctly before operating the equipment, otherwise serious damage from over-pressure could occur.
- 0.3.5 The set must not be run until commissioned, this could irreparably damage the pump set and/or system components/pipework connected to it.
- 0.3.6 The pumpset should be left switched ON for normal operation.
- 0.3.7 Ensure pumpset has an adequate water supply at all times to prevent dry running causing pump seal damage and water leakage.
- 0.3.8 Do not attempt to start pumps without liquid in volutes (pumps must be fully primed, see 1.2.2); mechanical seals must have a film of liquid between faces for proper operation and to prevent damage.
- 0.3.9 Minimum flow rate: Due to the risk of overheating, do not use the pump at a flow below the minimum flow rate. For cold water this is generally 10% of the pump flow rate as displayed on the pump data plate, on the pump body.
- 0.3.10 Portable telephones or other electro-magnetic equipment must not be used near the set to avoid corruption of program and unpredictable operation of unit.



0.4 CAUTIONS FOR MAINTENANCE

- 0.4.1 READ GENERAL SAFETY INFORMATION 0.0, WARNINGS 0.1 and CAUTIONS 0.2, 0.3 & 0.4
- 0.4.2 The unit should only be operated/maintained by a competent person; *A competent person is someone who is technically competent and familiar with safety practices and the hazards involved.*
- 0.4.3 To prevent seizing, pumpsets must not be left unused for long periods (e.g. 1 week).
- 0.4.4 The pumps must be run regularly to avoid stagnation of water in the pumps/pipework (e.g. daily).
- 0.4.5 Do not vent air from air valves on vessels. These are for adjustment of pre-set cushion pressures. If wrongly adjusted this will lead to incorrect operation of the pumpset and possible damage to pumps, pipework and system components from overheating and over-pressure.
- 0.4.6 Switch OFF pumpset before accessing pumps and/or control panel.
- 0.4.7 The pump inlet strainer must be periodically cleaned.
- 0.4.8 The mains water inlet strainer must be periodically cleaned.

1. INSTALLATION INSTRUCTIONS

These instructions are intended for the installer of this pressure booster set. Please follow them carefully.

The unit should only be installed by a competent person; *A competent person is someone who is technically competent and familiar with safety practices and the hazards involved.*

Failure to install the equipment as recommended below could invalidate the warranty provided by AquaTech-Pressmain to the purchaser.

1.1 ADDITIONAL WARNINGS

READ GENERAL SAFETY INFORMATION 0.0, WARNINGS 0.1 and CAUTIONS 0.2, 0.3 & 0.4

1.2 ADDITIONAL CAUTIONS

1.2.1 READ GENERAL SAFETY INFORMATION 0.0, WARNINGS 0.1 and CAUTIONS 0.2, 0.3 & 0.4.

1.2.2 Ensure the Y strainer (100um) and isolation valve (supplied as loose item) is installed on the inlet to the breaktank (see fig 1.3), failure to install these will cause the solenoid to jamb and overflow the break tank.

1.2.3 Ensure the quick release filter (supplied as loose item) is installed in the breaktank overflow warning pipe (see fig 1.3)

1.2.4 Mains water pressure to unit should be between 1.0 and 3.0Bar. Ensure a pressure reducing valve set at a maximum of 3.0Bar is installed on the inlet to the breaktank if the mains water supply pressure exceeds 3.0Bar.

1.2.5 Ensure the pump is primed before starting otherwise the pump seal will be damaged and cause a leak (see fig 1.1a).

1.2.6 The maximum static outlet pressure is 12 metres for AB5-45 (height from the pump discharge to the highest point of the system pipework), or 8 metres for AB5-35.

1.2.7 Ensure the control vessel air charge is set correctly (1.3Bar) otherwise erratic operation will occur (pump will not start/stop correctly).

1.2.8 We recommend system pipework should be 22mm only reducing to 15mm at the terminal fitting.

1.2.9 Ensure the pressure vessel that is factory fitted to the pump assembly is still tight after transit, it should be hand tight only, DO NOT over tighten the pressure vessel, this will lead to damage to the vessel/fitting and subsequent leakage (see Fig 1.1b).

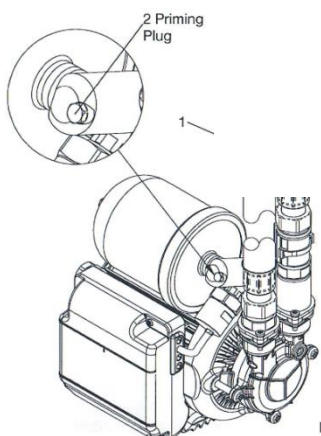

Fig 1.1a Pump priming plug

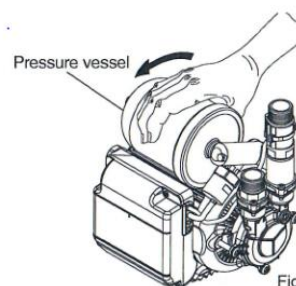

Fig 1.1b Vessel hand tight only

1.3 PROCEDURE

1.3.1 OFF-LOADING AT SITE

Do not lift pumpset by pipework. Lift the pumpset by the container pallet using a pallet/forklift or crane by passing strops underneath the skid using spreader bar.
Failure to utilise these facilities could result in damage.

1.3.2 LOCATION

If the set is to be installed in an unheated room, ensure that there is adequate frost protection. The location of the equipment should have adequate drainage, bunding or other appropriate measures to protect assets and the building fabric in the event of leakage or water spillage. Failure to provide such measures may result in water damage to property and assets.

Ensure that location for pumpset provides adequate clear space to accommodate unit with reasonable access to all parts; AquaTech-Pressmain recommend a minimum distance of 500mm all round. There must be sufficient room to: -

- fully open panel door;
- lift and withdraw pumps;
- withdraw diaphragms from vessels.

Any Hydraulic Accumulator supplied should be located as near as possible to the discharge side of the pumpset.

Should any of these location conditions not be satisfied AquaTech-Pressmain reserve the right to charge labour on any warranty work required on the pumpset.

1.3.3 FIXING

Lugs are provided for wall fixing on the back of the panel. Install the set on a flat, even and level surface, in a location that is easily accessible. If floor mounted then install on a raised plinth to keep set above damp floor.

Locate unit in position. If necessary, level by inserting packing strips adjacent to bolt positions. Firmly attach pumpset to wall/base.



Fig. 1.2



Fig. 1.3a & b Mains water connection showing strainer and isolating valve installed & Quick release filter attached to overflow warning pipe (supplied loose).

1.3.4 PIPEWORK

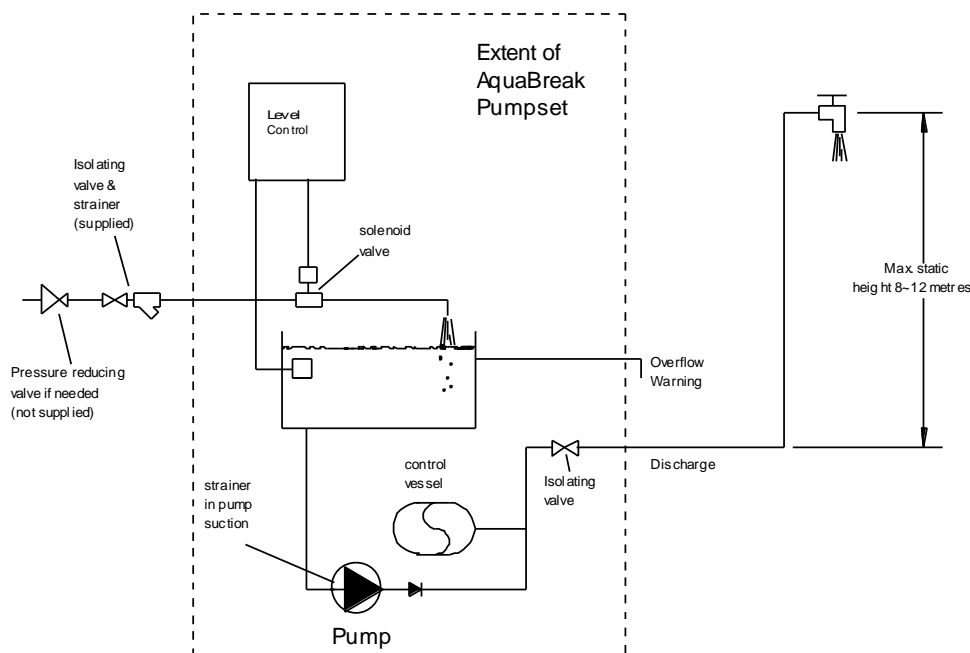

Fig. 1.4 Typical Pipework arrangement

- 1.3.4.1** Ensure the isolation valve & strainer (supplied loose) is fitted to the mains water inlet. Particles/debris must not enter the mains water solenoid valve, otherwise it may stick open and cause leakage/flooding.
- 1.3.4.2** Mains water pressure should be 1Bar minimum, 3Bar maximum. If the pressure exceeds 3Bar then a pressure reducing valve (not supplied) must be fitted before the mains water inlet to the pumpset.
- 1.3.4.3** Ensure the quick release filter (supplied as loose item) is installed in the breaktank overflow warning pipe and connected to drain with an air-break e.g. tundish in a conspicuous location.
- 1.3.4.4** **Under no circumstances fit an extra non-return valve**, to the discharge, as it may interfere with the correct operation of the non-return valve already fitted as standard in the pumpset.
- 1.3.4.5** Connect site pipework to mains water inlet and discharge, ensuring adequate support is provided to avoid imposing pipe strain on pumpset. The connecting pipework should not be smaller than that of the pumpset i.e. 15mm mains water inlet, 22mm discharge
- 1.3.4.6** Where Hydraulic Accumulator(s)/Expansion Vessel(s) are supplied as a loose item, they must be installed/connected correctly before operating the equipment, otherwise serious damage from over-pressure/pump overheating could occur.
- 1.3.4.7** All hydraulic accumulators and expansion vessels fitted to the system must have isolating and drain off valves to enable them to be serviced and removable pipework to enable the diaphragm to be replaced.



Fig. 1.5a & b Isolation valve on pipework & Flexible hose with drain cock on vessel (non-flow through vessel shown)

1.3.5 FLOW THROUGH VESSELS

Some installations require flow through vessel(s) supplied loose for site fitting into the discharge pipework via a flowjet isolation and drain valve. The number and size of vessels supplied varies according to site conditions.

Ensure “O-ring” is in place inside valve to prevent leakage.

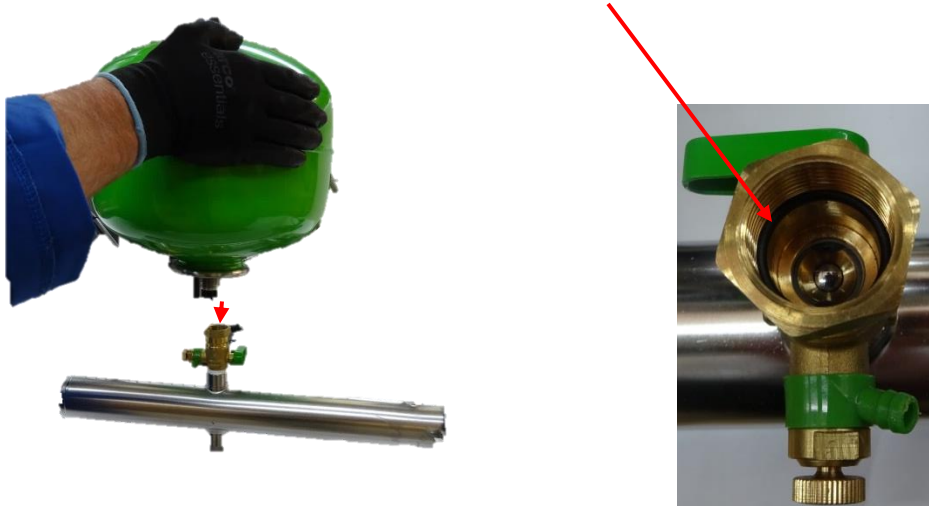

Fig. 1.6a & b Fit flow through vessel into discharge system pipework flowjet valve.

Set up the vessel so the air charge filling valve (top) is accessible for future maintenance. All vessels must have isolating and drain off valves fitted to enable them to be serviced.

Set the air cushion pre-charge pressure to the correct level (see section 2.4), dependent on the application required for the vessel. Refer to the Operating parameters at the back of this manual or contact Aquatech-Pressmain for advice.

1.3.6 ELECTRICAL

WARNING: DO NOT TOUCH ANY LIVE PARTS FOR AT LEAST 5 MINUTES AFTER SWITCHING OFF THE POWER TO ALLOW CAPACITORS TO DISCHARGE

READ GENERAL SAFETY INFORMATION 0.0, WARNINGS 0.1 and CAUTIONS 0.2, 0.3 & 0.4

1.3.6.1 All wiring must comply with the latest edition of local wiring Regulations.

1.3.6.2 Wear anti-static wrist strap at all times to avoid static discharge causing problems with the built in electronic program.

1.3.6.3 Connect incoming electrical mains supply to identified terminals on isolator IS1 in control panel (see fig. 1.7). Ensure voltages and frequency indicated on the motor nameplates and wiring diagrams correspond with supply mains data and that the supply fuse type & rating is correct for the total current rating of the equipment.

1.3.6.4 Complete any required earth bonding.

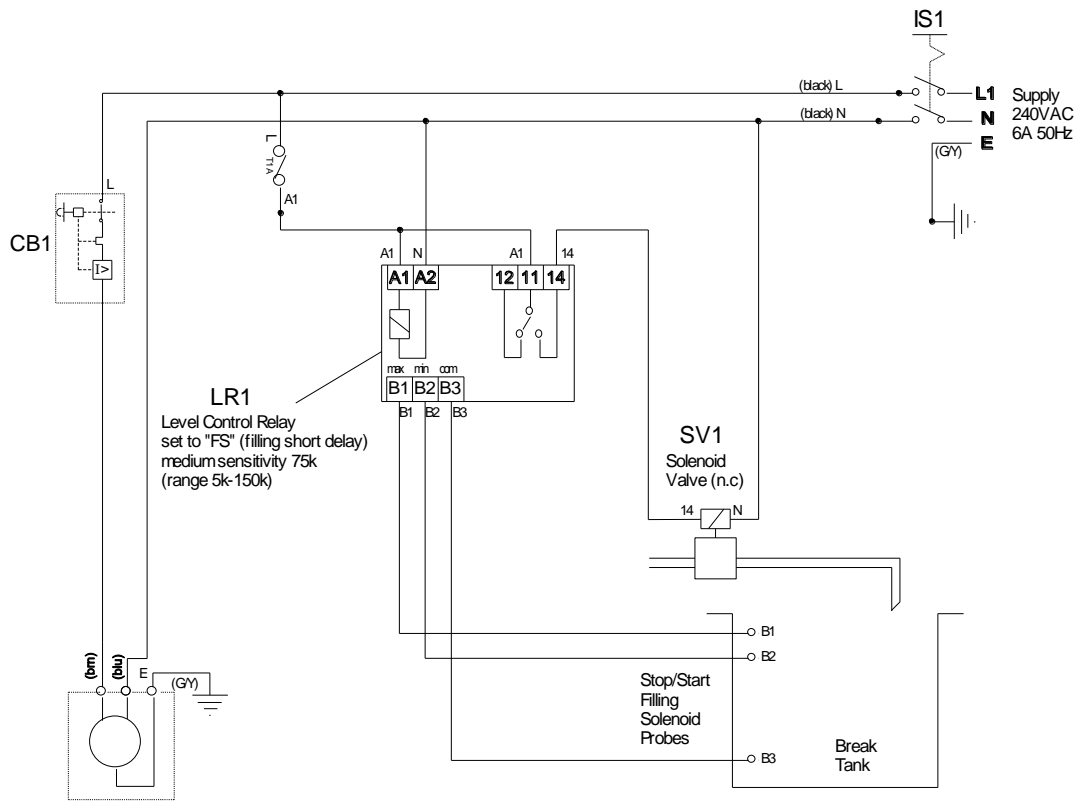

Fig. 1.7 Typical example of AquaBreak electrical connections.

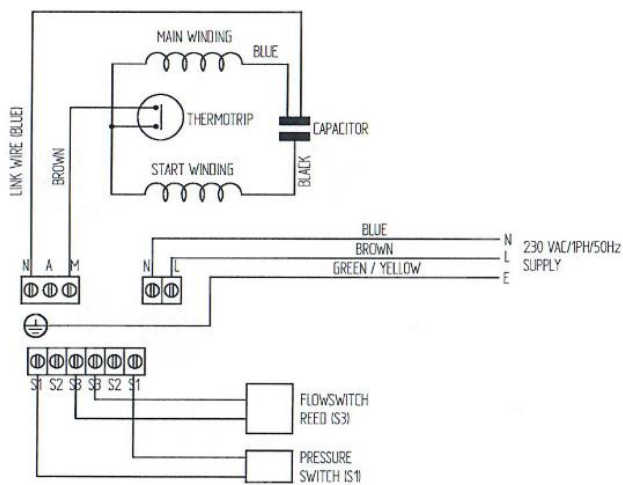

Fig. 1.8 Typical example of AquaBreak pump motor terminal box connections.

2. USER INSTRUCTIONS

2.1 CUSTOMER ASSURANCE

AQUATECH-PRESSMAIN ASSURE YOU THAT IF ANY PART OF THIS EQUIPMENT BECOMES DEFECTIVE DUE TO FAULTY MANUFACTURE OR MATERIALS WITHIN 24 MONTHS FROM THE DATE OF INVOICE OR 12 MONTHS FROM DATE OF COMMISSIONING BY AUTHORISED AQUATECH-PRESSMAIN AGENT, THE PART WILL BE REPAIRED OR REPLACED

The only conditions are: -

- ◆ The equipment must have been installed, commissioned, operated and maintained as recommended by **AquaTech-Pressmain**.
- ◆ The equipment must not have been neglected, misused, modified, or used for any other purpose than its original application.
- ◆ The commissioning should be carried out within 6 months of the date of invoice by an authorised **AquaTech-Pressmain** agent.
- ◆ This Assurance does not apply to those items not supplied by us or to defects arising from parts not made or approved by **AquaTech-Pressmain**. The individual manufacturers own policies for dealing with defects will apply.
- ◆ Any part repaired or replaced under these Assurances will be covered for the balance of the appropriate Assurance period.
- ◆ If we have any disagreement about these Assurances which we are unable to resolve we will both abide by the decision of an agreed Arbitrator or, if we are unable to agree, one appointed by the Building and Engineering Services Association (B & ES) Arbitration Scheme Rules.
- ◆ These Assurances are in addition to, and do not detract from, the contractual rights you have under Statute or at common law.
- ◆ Failure to comply with the installation, commissioning and maintenance procedures will invalidate the warranty.

For full details please see the AquaTech-Pressmain "CONDITIONS OF SALE"

2.2 COMMISSIONING

The unit should only be commissioned by a competent person; *A competent person is someone who is technically competent and familiar with safety practices and the hazards involved.*

- 2.2.1 READ GENERAL SAFETY INFORMATION 0.0, WARNINGS 0.1 and CAUTIONS 0.2, 0.3 & 0.4 plus the additional warnings and cautions 1.1 & 1.2
- 2.2.2 This pumpset has been tested in the factory prior to delivery. However, it is impossible to simulate the actual on-site conditions, especially if they are unusual. Therefore we can (if required) **commissioned the pumpset**, make any necessary adjustments and leave the set in operational order. Please see contact information at the end of this manual.
- 2.2.3 Should you wish to commission the pumpset yourself, then please follow the instructions below: You must ensure that;
 - 2.2.3.1 the equipment has been correctly installed;
 - 2.2.3.2 a written scheme of examination has been obtained where required under the Pressure Systems Safety Regulations;
 - 2.2.3.3 any necessary chlorination or other treatment has been completed;
 - 2.2.3.4 the system pipework has been thoroughly flushed prior to final connection of the pumpset to ensure any contaminants/chemical residues and foreign particles have been completely removed;
 - 2.2.3.5 an adequate water supply (1 to 3Bar) and permanent electricity supply (230vac 1 phase 50Hz 6 Amp) are available;
 - 2.2.3.6 the pipework etc in the building being served by the pumpset is capable of accepting the generated pressures.
- 2.2.4 with the power and water OFF, check tightness of all mechanical and electrical connections, to ensure they have not loosened during transit.
- 2.2.5 with the pumpset switched off (IS1) and the motor circuit breaker switched off (CB1), close the discharge isolating valve.
- 2.2.6 close the mains water inlet isolating valve, check and clean the strainer, re-install strainer ensuring it is leak free.
- 2.2.7 check the control vessel air charge is correct (1.3Bar) when there is no pressure on the discharge.
- 2.2.8 check and clean pump suction strainer/inlet filter (See Fig 2.1)
- 2.2.9 slowly open mains water inlet valve, switch on unit to allow solenoid valve to open and fill the mains water break tank.
- 2.2.10 ensure the pump is primed (filled with water) before starting otherwise the pump seal will be damaged and cause it to leak (see fig 1.1a).
- 2.2.11 once the pump is fully primed, switch the pump motor circuit breaker (CB1) on and allow the pump to pressurise against the closed discharge valve. The pump should stop when closed valve pressure has been achieved (plus a short run on time).
- 2.2.12 ensure all system outlets are closed, SLOWLY open the pumpset discharge valve to allow the pump to pressurise the system pipework. Check for leaks and repair them.
- 2.2.13 open and close each system outlet in turn allowing water to flow from each outlet until all the air is purged. As each outlet is opened and closed the pump should start and stop (stops after a short time delay).
- 2.2.14 if any outlet on the system is opened and closed this should cause the pump to start and stop and the breaktank to refill as necessary. If this is so then the pumpset is working normally.
- 2.2.15 check for normal operation and that no leaks are present, check all isolation valves on the pumpset are open and all covers are fixed in place before leaving the installation unattended.

2.3 OPERATING INSTRUCTIONS

These pumpsets are used for increasing the supply pressure of cold potable water whilst also providing back flow protection to fluid category 5.

The unit should only be operated by a competent person; *A competent person is someone who is technically competent and familiar with safety practices and the hazards involved.*

2.3.1 ADDITIONAL WARNINGS

DO NOT TOUCH ANY LIVE PARTS FOR AT LEAST 5 MINUTES AFTER SWITCHING OFF THE POWER

READ GENERAL SAFETY INFORMATION 0.0, WARNINGS 0.1 and CAUTIONS 0.2, 0.3 & 0.4.

2.3.2 ADDITIONAL CAUTIONS

2.3.2.1 READ GENERAL SAFETY INFORMATION 0.0, WARNINGS 0.1 and CAUTIONS 0.2, 0.3 & 0.4.

2.3.2.2 Ensure the pump is primed before starting otherwise the pump seal will be damaged and cause a leak.

2.3.2.3 Seal faces are lubricated by the pumped liquid, as such new seals will leak slightly until “run-in” there after the leakage should be small enough to evaporate and remain un-noticed.

2.3.3 NORMAL OPERATION

This pumpset increases and maintains the supply pressure to a preset 'Duty' pressure whilst also providing back flow protection to fluid category 5.

The pumpset consists of a pump with built in pressure and flow switches, a mains water break tank with solenoid filling valve and controls, all mounted in a steel enclosure together with associated discharge valve and external mains water isolation valve & strainer. The pumpset can be wall or floor mounted.

2.3.3.1 For “normal” operation, all pumpset inlet and discharge valves should be left open, all hydraulic accumulator/expansion vessel isolating valves should be left open, and drain cock/valves should be left closed. Should it be necessary to have a situation that is not “normal” operation, then we would strongly recommend attendance to site by our trained/authorised service personnel. Please contact AquaTech-Pressmain for more details.

2.3.3.2 Once installed and commissioned correctly, the pumpset automatically starts and stops the pump as system outlets are opened and closed. The breaktank automatically fills as and when required.

2.3.3.3 **Dry run protection.** The pump has automatic dry run protection built in should the mains water breaktank run dry for any reason. Dependent upon the installed pump type, two scenarios can occur following initiation of dry run protection. 1) The pump will stop and lock-out, this requires manually restarting by switching off the power supply for 10 seconds then switching back on again. 2) The pump will automatically attempt to restart every 5 minutes for 3 attempts before shutting down and requiring manually switching off, wait 10 seconds, switch on to reinitiate the start sequence.

If the pump continues to initiate the dry run protection then it may need to be primed again (see commissioning 2.2), have a blocked strainer or no water is entering the break tank.

2.3.3.4 The tank level control relay (LR1) controls the operation of the solenoid valve. The LED indicator is OFF when there is no power, slow flashing for ON with tank full, fast flashing for short timing period, permanently lit for ON and filling tank.

2.3.4 TROUBLE SHOOTING GUIDE

Symptoms	Possible Cause	Check
No water, pump will not start	Electrical supply off	Check power supply, electrical isolator, fuses, RCD, motor circuit breaker, wiring connections
	Pump seized (motor buzzes)	Pump has not been run regularly (weekly). Contact Aquatech Pressmain service
	Pump seized (internal motor thermotrip operated)	Pump has not been run regularly (weekly). Contact Aquatech Pressmain service
	Dry run protection initiated (see 2.3.3.3)	Breaktank is empty, check inlet valve/strainer and solenoid valve operation. Check mains water supply. Check pump suction strainer/inlet filter
	Maximum system head exceeds 8m for AB5-35 or 12m for AB5-45.	Pump start Pressure switch will not operate if maximum system head is exceeded.
	Pump stopped on low water (dry run), no water in break tank	Tank Level Control relay fault, switch power off, wait 10 seconds and switch power on again to reset control relay.
No water, pump does run	Pump air-locked	Vent/prime pump to remove all air. Check pump suction strainer/inlet filter
Reduced/intermittent flow	Pump partially air-locked	Vent/prime pump to remove all air
	Mains water/Pump inlet strainer blocked/partially blocked	Clean mains water/pump inlet strainer (section 2.4)
	Air in system	Purge air from all system pipework
	Dry run protection initiated (see 2.3.3.3)	Breaktank is empty, check inlet valve/strainer and solenoid valve operation. Check mains water supply
Pump continues to run with all outlets closed or pump cycles on and off (hunts)	Leak in system	Check all system pipework and outlets for leak
	Control vessel air-charge incorrect	Check air charge pressure in vessel
	Jammed flow switch	Remove discharge hose and check flow switch for free movement, no debris
	Jammed non-return valve	Remove non-return valve and check for free movement, no debris
	Damaged flow or pressure switch	Contact Aquatech Pressmain service

If a problem persists, contact **AQUATECH-PRESSMAIN** service department quoting the serial number **WN/SN: _____** (on control panel fascia)

2.4 MAINTENANCE INSTRUCTIONS

DO NOT TOUCH ANY LIVE PARTS FOR AT LEAST 5 MINUTES AFTER SWITCHING OFF TO ALLOW CAPACITORS TO DISCHARGE.

The unit should only be maintained by a competent person; *A competent person is someone who is technically competent and familiar with safety practices and the hazards involved.*

2.4.1 ADDITIONAL CAUTIONS

2.4.1.1 READ GENERAL SAFETY INFORMATION 0.0, WARNINGS 0.1 and CAUTIONS 0.2 to 0.4.

2.4.2 PROCEDURE

Every 6 months the pumpset should be maintained by authorised AquaTech-Pressmain service agents - see Servicing (Section 3.)

Pump inlet filter/suction strainer

The pump inlet filter should be regularly checked to remove any build-up of debris.

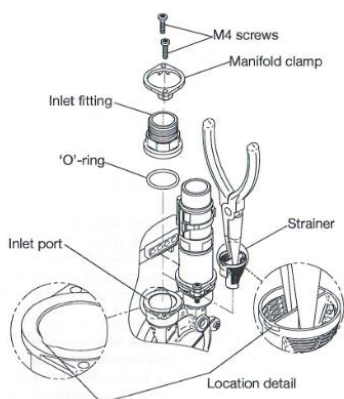

Fig 2.1 Pump inlet filter/suction strainer

Mains water inlet strainer

The mains water inlet strainer should be regularly checked to remove any build-up of debris.



Fig 2.2 Mains water inlet isolation valve & strainer

Control vessel

Air Charge Pressure. The correct charge pressure provides reliable operation of the system and a prolonged lifetime of the diaphragm. This should be checked regularly to avoid problems such as unstable pump operation.

- To adjust air charge pressure:** switch off the pumpset, release system pressure on water side by opening a system outlet, and leave open. The water inside the bladder will be pushed back by the air charge pressure. Remove cap on the filling valve, set air charge pressure refilling using dry air or nitrogen. Screw cap firmly on filling valve. Close the system outlet. Close pumpset discharge valve, switch pumpset back on and slowly open discharge valve to the system.

3. SERVICING

3.1 MAINTENANCE AND CARE OF YOUR EQUIPMENT

The AquaTech-Pressmain equipment that is described in this instruction booklet has been manufactured and tested to the highest standards of design and quality. It will give trouble free operation over many years provided it is maintained regularly from when it is commissioned. To keep it operating efficiently in a safe, economical and environmentally friendly condition, regular maintenance is an essential part.

AquaTech-Pressmain along with its' service division, Acorn Pressurisation Services are the official providers of commissioning and maintenance services. (see below).

Several companies operating under the Aquatronic Group Management structure are available to fulfil a wide range of servicing and maintenance requirements, as detailed below.

3.2 LEGAL REQUIREMENTS

Hydraulic Accumulators/Expansion Vessels installed as part of/in conjunction with this equipment, with Pressure x Volume above 250 Bar-litres, require formal inspection in accordance with a "Written Scheme of Examination". This is a Legal Requirement on the part of the Owner/User under the "Pressure Systems Safety Regulations" (PSSR). A "Written Scheme" and regular inspection can be provided by either Acorn Pressurisation Services (combined maintenance and inspection) or ESIS Ltd (inspection only), see details below.



Plant Servicing & Inspection
ACORN PRESSURISATION SERVICES,
 AGM House, Essex, London Rd, Copford, Colchester CO6 1GT.
 Ph: 01206 215151
 10 Wheel Forge Way, Manchester. M17 1EH. Ph: 0161 226

4727

Acorn provides maintenance and installation of all types of packaged water pumping equipment for building services. Its specialist fields are Pressure booster equipment and sealed systems for heating and chilled water distribution systems.

Regular servicing of any plant for essential services is vital because wear and tear are very gradual processes. With preventative maintenance, the costs are small and benefits in reliability, safety and economy can be significant. Acorn Pressurisation Services can provide a complete package of schemes for preventative maintenance on all AquaTech-Pressmain and other makes of equipment.



Pressure Vessel Inspection
ESIS ENGINEERING SAFETY & INSPECTION SERVICES LTD,
 AGM House, London Rd, Copford, Colchester, Essex, CO6 1GT.
 Phone: 01206 215141

Under the Pressure Systems Safety Regulations, expansion vessels and hydraulic accumulators, generally 250 bar-litres and greater, and protection devices, require a Written Scheme of Examination before they can be operated. ESIS Inspection and Insurance Services Limited specifications can provide the means to comply with these regulations. These services can be extended to cover other units e.g. air pressure receivers etc.

3.3 SERVICE CONTACTS

For service during warranty period contact: AQUATECH-PRESSMAIN Service Department
 Head Office Tel: 01206 215121

For regular servicing, contact service division: ACORN PRESSURISATION SERVICES
 Head Office Tel: 01206 215151 Manchester Office Tel: 0161 226 4727

who will be pleased to give you expert advice on this or any other servicing matter.

4. DISPOSAL

Disposal of this product or parts of it must be carried out in accordance with the following guidelines:

Use the local public or private recycling/waste collection service.

In case such a recycling/waste collection service does not exist or cannot handle the materials used in this product, please deliver the product or any hazardous material from it to your nearest AquaTech-Pressmain office.

EU Declaration of Conformity

We, Aquatronic Group Management Plc, declare that the Equipment detailed below:

BREAKTANK AND PUMPSET
MODEL: AquaBreak AB5

Complies with the requirements of the following European Directives:
Machinery Directive 2006/42/EC
Low Voltage Directive 2014/35/EU
Electro Magnetic Compatibility Directive 2014/30/EU.



7/12/16

I.D.Taylor, I.Eng. MIET, Director

Aquatronic Group Management Plc
T/A AquaTech-Pressmain
AGM House, London Rd, Copford, Colchester, Essex CO6 1GT UK
Telephone: 01206 215121

OPERATING PARAMETERS

SERIAL No. **MODEL** AB5

THE SERIAL & MODEL NUMBERS MUST BE QUOTED WHEN REQUESTING ASSISTANCE

ELECTRICAL DATA:

Supply	230	volts	1	Ph	50	Hz
Full load current of pumpset	6	Amps				
Max. pumpset loading:	0.55	Kw		Method of starting:	DOL	

NOISE LEVEL: less than 70 db(A) unless otherwise stated

NOMINAL FLOW RATE: 0 to 26 litres/min

PRESSURE SETTINGS:

AS FACTORY SET

	AB5-45	(AB5-35)
Pump Duty pressure	1.5Bar	(1.0Bar)
Control vessel:	1.3Bar	(1.0Bar)
Pump closed valve press.	4.5Bar	(3.6Bar)

- ❖ On commissioning it may be found necessary to modify these settings. Providing this information is left with the equipment, the figures will be updated by the commissioning engineer.

Updated by commissioning engineer Date