AQUASPILL AS SERIES



SPILL BACK SYSTEM PRESSURISATION UNITS WITH VARIABLE SPEED PUMPS

SPILL BACK SYSTEM PRESSURISATION UNITS

AQUASPILL AS SERIES WITH VARIABLE SPEED PUMPS

Overview

Decades of experience design and installation from Pressmain and Aquatech have now been combined to produce a new 21st Century version of the spill type pressurisation unit. The AquaSpill AS series pressurisation units are primarily designed for district heating or cooling systems where large system contents or high operating temperatures rule out conventional sealed expansion vessels. The new modularised design mean that standard configurations of pump, buffer and tank modules can be mixed and matched for heating or chilled water systems with a total water content between 1,000,000 litres at 60°C boiler flow temperature and 390,000 litres at 120°C.

Bespoke units can also be designed with unlimited system content and boiler flow temperatures up to 200°C and cold fill pressures up to 25.0 bar. Each unit is designed to suit the available space or system content. The AquaSpill AS will maintain optimum system conditions. On rising system temperature the expanding water is spilled automatically into spill tank/s, and as the system cools the spilled water is automatically pumped back into the system. Any loss of water from the system will be automatically made-up. During the above operations the pressure variation does not normally exceed 0.8 bar.

Features

- 304 Stainless Steel Spill Tank
- Maximum expanded volume (acceptance): normally 20,000 litres
- Maximum system cold fill pressure: 8.0 bar
- Intermediate cooling vessel used when boiler flow temperature exceeds 90°C to minimise system heat loss
- Automatic duty pump change over to even wear
- Anti pump-seizure pulsing
- Low water level pump protection switch mounted in Spilltank
- High water level alarm switch mounted in Spilltank
- Automatic delay on high & low pressure alarms up to 4 minutes to allow circulator pump pressures to stabilise
- Variable flow spill control to maintain constant system pressure
- Variable speed pump control to maintain constant system pressure
- Integral automatic water make-up system
- Designed, manufactured & tested to ISO9001 Standards
- CE marked for full compliance with all relevant European Directives
- Optional M & E 3 specification

Specification

AquaSpill AS series incorporates variable speed pumps and optional variable flow spill technology all controlled by the tried and trusted Aquatech 2020+ microprocessor.

Typically with twin single phase variable speed pumps having automatic alternation of duty pump & anti-seizure pulsing, delayed initiation of high and low system pressure cut outs both linked to single pole volt-free relays, hand-Off-Auto switches for each pump, pump Run & Tripped L.E.D.s, hours run meters, interlocked door isolator, low water level sensing in Spilltank coupled to volt free relay, alarm buzzer, alarm mute and reset buttons/indicators, digital pressure, fault and parameter indicator. Combined spill and mains water break tank, float valve with type AA air gap, overflow connection, and low water level protection, electromagnetic spillvalve with strainer & isolating valves, IP55 powder coated control cabinet, interconnecting piping to spill tank, supplied as modules for ease of installation. Set assembled, tested and commissioned in accordance with ISO9001 Standards & Pressure Equipment Directive. Spill tanks are manufactured in 304 stainless steel.



Optional Aquasphere Blanket

This is a single layer ball blanket which floats on the spill tanks' surface, which will significantly reduce liquid evaporation & oxygen ingress. A National Engineering Laboratory study showed a reduction in evaporation of over 80% when compared to a tank without an Aquasphere blanket. Absorption of free oxygen into hot water contained in open spill tanks can lead to serious corrosion of pipes, valves and boiler jackets. Tests have also shown that a single layer blanket can reduce oxygen absorption by up to a factor of 20. The Aquasphere Blanket system can therefore be seen as a highly effective two way barrier preventing both evaporation from and absorption into a liquid.

INLET WITH AIR GAP



FORK LIFT SLOTS



LIFTING EYES



HINGED INSPECTION LID



CONTROL PANEL FASCIA

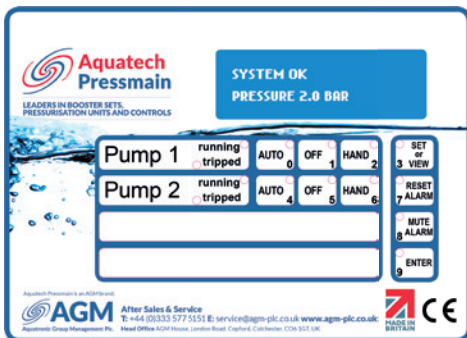

Typical control panel fascia layout is shown below, using the Aquatech Pressmain 2020+ Micro-controller.

DRAIN DOWN VALVE



Integral base with fork lifting points

AQUASPILL AS SELECTION

Selection of the right product is crucial, the complexity of the system flow temperatures and pressures means there are infinite combinations that can be achieved. If you provide us with the information we will provide you with the right product for your application.

What we need to know;-

System Content in litres	
Boiler/Chiller output kilowatts	
Flow temperature	
Return temperature	
Static height of system	
Maximum operating pressure of system	
Chemical additives to system	
Available floor space footprint	
Access restrictions height, width etc.	

Based on the answers to these questions we will make the most appropriate selection on your behalf.

TYPICAL SCHEMATIC PIPEWORK ARRANGEMENT

WORK REQUIRED ON SITE

- 1 Position pressurisation unit on raised plinth
- 2 Attach spill tank(s) where supplied loose
- 3 Connect correctly sized mains water supply to float valve, minimum pressure of 1 Bar required.
- 4 Connect overflow warning pipe to drain.

- 5 Connect to system pipework on underside of return pipe.
- 6 Connect mains electricity supply, boiler/chiller interlock wiring and BMS volt frees as required.
- 7 Contact Aquatech Pressmain to have unit commissioned when ready.

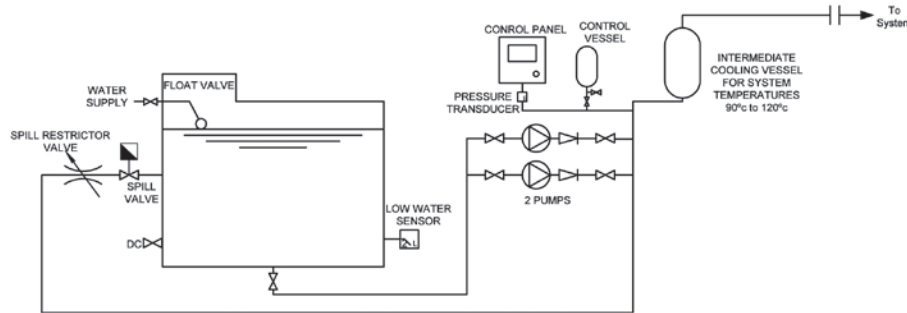

ELECTRICAL CONNECTIONS

Electrical supply for AS2AV, Single Phase, 230 Volt AC, 50Hz or 3 Phase, 400Volt AC 50Hz motors for larger applications. Please ask Aquatech Pressmain for more details.

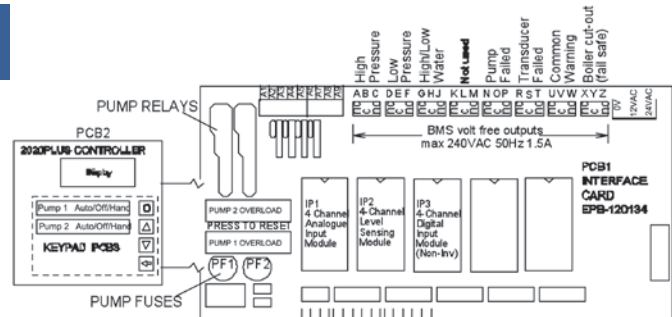

Typical electrical connections for AquaSpill AS

Typical Boiler Interrupt Circuit
(Wiring by controls contractor)

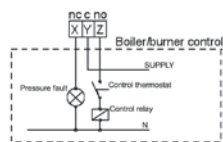

CONSTRUCTION STANDARDS FOR AQUASPILL AS PRESSURISATION UNITS

COMPONENT	MODEL/SERIES	STANDARDS/CLASS	REMARKS
Quality System	Manufacturing	ISO 9001	Cert No. FM33090
Electrical Safety Standard		BS EN 60204-1:2006	EC Declaration of Conformity
Low Voltage Directive		73/23/EEC & 93/68/EEC	EC Declaration of Conformity
EMC Directive 89/336/EEC		EN61000-6-3 & EN61000-6-1	EC Declaration of Conformity
Pressure Equipment Directive		97/23/EC	EC Declaration of Conformity
Spill tank		304 stainless steel	Bespoke sizing available
Mains water float valve	Drop arm	Equilibrium	Type AA air gap
Pipework		Stainless steel	
Motors	Variable Speed EuP	TEFC IP44, Class F Insulation	Thermal overload protected
Control cabinet	2020+	IP55	425x425x200mm
Isolator Door Interlocked	GHA-030250	CE, UL, CSA, BS, IEC, VDE	
Microprocessor Controller	2020+	89/336/EEC compliant	
Pressure Transducer	392 - 10Bar	SS/Ceramic	
Control Vessel	VR 10Bar	BS:EN13831:2007	CE marked



AGM House, London Road, Copford, Colchester CO6 1GT
T: +44 (0)1206 215121 E: info@aquatechpressmain.co.uk www.aquatechpressmain.co.uk